

---

# AIC

# MALAYSIA

PHONE : 6-03-7846 5233
TELEX : PENAWA MA 30128
FAX : 6-03-7847 2997
AFTN : WMKKYAYS
COMM : AIRCIVIL
KUALA LUMPUR

AERONAUTICAL INFORMATION SERVICES  
DEPARTMENT OF CIVIL AVIATION  
BLOCK A  
AIR TRAFFIC CONTROL CENTRE COMPLEX  
SULTAN ABDUL AZIZ SHAH AIRPORT  
47200 SUBANG  
SELANGOR DARUL EHSAN  
MALAYSIA

18 / 2005
21 JUL

---

## HELICOPTER PERFORMANCES AND OPERATIONS

### 1. INTRODUCTION

- 1.1 This AIC is issued in the exercise of the powers conferred under Section 24O of the Civil Aviation Act 1969. Pursuant to Regulation 51 of the Civil Aviation Regulations 1996, and ICAO Annex 6, Part I and III, this AIC is to provide guidelines to be adopted by operators for the safe conduct of the operations. This is **to supplement** those stipulated in Regulation 51 of the Civil Aviation Regulations 1996.
- 1.2 This AIC sets forth a means that would be acceptable to DCA for the purpose of complying of such requirements.

### 2. DEFINITION

- 2.1 **Defined point after take-off.** The point, within the take-off and initial climb phase, before which the helicopter's ability to continue the flight safely, with one engine inoperative, is not assured and a forced landing may be required.
- 2.2 **Defined point before landing.** The point, within the approach and landing phase, after which the helicopter's ability to continue the flight safely, with one engine inoperative, is not assured and a forced landing may be required.
- 2.3 **Elevated heliport.** A heliport located on a raised structure on land.
- 2.4 **En-route phase.** That part of the flight from the end of the take-off and initial climb phase to the commencement of the approach and landing phase.
- 2.5 **Flight crew member.** A licensed crew member charged with duties essential to the operation of an aircraft during a flight duty period.
- 2.6 **Flight duty period.** The total time from the moment a flight crew member commences duty, immediately subsequent to a rest period and prior to making a flight or a series of flights, to the moment the flight crew member is relieved of all duties having completed such flight or series of flights.
- 2.7 **Final approach and take-off area (FATO).** A defined area over which the final phase of the approach manoeuvre to hover or landing is completed and from which the take-off manoeuvre is commenced. Where the FATO is to be used by Performance Class 1/Group A helicopters, the defined area includes the rejected take-off area available.
- 2.8 **Ground handling.** Services necessary for an aircraft arrival at, and departure from, an airport, other than air traffic services.

- 2.9 **Helideck.** A heliport located on a floating or fixed off-shore structure.
- 2.10 **Heliport.** An aerodrome or a defined area on a structure intended to be used wholly or in part for the arrival, departure and surface movement of helicopters.
- 2.11 **Heliport operating minima.** The limits of usability of a heliport for:
- 2.11.1 take-off, expressed in terms of runway visual range and/or visibility and, if necessary, cloud conditions;
- 2.11.2 landing in precision approach and landing operations, expressed in terms of visibility and/or runway visual range and decision altitude/height (DA/H) as appropriate to the category of the operation;
- 2.11.3 landing in approach and landing operations with vertical guidance, expressed in terms of visibility and/or runway visual range and decision altitude/height (DA/H); and
- 2.11.4 landing in non-precision approach and landing operations, expressed in terms of visibility and/or runway visual range, minimum descent altitude/height (MDA/H) and, if necessary, cloud conditions.
- 2.12 **Landing decision point (LDP).** The point used in determining landing performance from which, if a power-unit failure occurring at this point, the landing may be safely continued or a balked landing initiated.
- 2.13 **Performance Class 1/Group A helicopter.** A helicopter with performance such that, in case of critical power-unit failure, it is able to land on the rejected take-off area or safely continue the flight to an appropriate landing area, depending on when the failure occurs.
- 2.14 **Performance Class 2/Group A(Restricted) helicopter.** A helicopter with performance such that, in case of critical power-unit failure, it is able to safely continue the flight, except when the failure occurs prior to a defined point after take-off or after a defined point before landing, in which cases a forced landing may be required.
- 2.15 **Performance Class 3/Group B helicopter.** A helicopter with performance such that, in case of power-unit failure at any point in the flight profile, a forced landing must be performed.
- 2.16 **Safe forced landing.** Unavoidable landing or ditching with a reasonable expectancy of no injuries to persons in the aircraft or on the surface.
- 2.17 **Take-off and initial climb phase.** That part of the flight from the start of take-off to 300 m (1000 ft) above the elevation of the FATO, if the flight is planned to exceed this height, or to the end of the climb in the other cases.
- 2.18 **Take-off decision point (TDP).** The point used in determining take-off performance from which, if a power-unit failure occurring at this point, either a rejected take-off may be made or a take-off safely continued.
- 2.19 **VTOSS.** The minimum speed at which climb shall be achieved with the critical power-unit inoperative, the remaining power-units operating within approved operating limits.
- 2.20 **Distance DR.** DR is the horizontal distance that the helicopter has travelled from the end of the take-off distance available.

- 2.21 **Landing distance available (LDAH).** The length of the final approach and take-off area plus any additional area declared available and suitable for helicopters to complete the landing manoeuvre from a defined height.
- 2.22 **Take-off distance available (TODAH).** The length of the final approach and take-off area plus the length of helicopter clearway (if provided) declared available and suitable for helicopters to complete the take-off.
- 2.23 **Touchdown and lift-off area (TLOF).** A load bearing area on which a helicopter may touch down or lift off.
- 2.24 **Vy.** Best rate of climb speed.
- 2.25 **Landing distance required (LDRH).** The horizontal distance required to land and come to a full stop from a point 10.7 m (35 ft) above the landing surface. (Applicable to performance Class 1 helicopters only)
- 2.26 **Take-off distance required (TODRH).** The horizontal distance required from the start of the take-off to the point at which VTOSS, a height of 10.7 m (35 ft) above the take-off surface, and a positive climb gradient are achieved, following failure of the critical power-unit at TDP, the remaining power-units operating within approved operating limits.

(Applicable to performance Class 1 helicopters only)

### 3. GENERAL REQUIREMENTS

- 3.1 **Rotor engagement.** A helicopter rotor shall not be turned under power without a qualified pilot at the controls.
- 3.2 **Refuelling with passengers on board or rotors turning.** A helicopter shall not be refuelled when passengers are embarking, on board, disembarking or when the rotors are turning.
- 3.3 **In-flight operational instructions.** Operational instructions involving a change in the Air Traffic Services (ATS) flight plan shall, when applicable, be coordinated with appropriate ATS unit before transmission to the helicopter. When the above coordination has not been possible, operational instructions do not relieve a pilot of the responsibility for obtaining an appropriate clearance from an ATS unit, if applicable, before making a change in flight plan.
- 3.4 **Minimum flight altitudes.** The method for establishing the minimum flight altitudes shall be approved by the Department of Civil Aviation (DCA). DCA shall approve such method only after careful consideration of the probable effects of the following factors on the safety of the operation in question:
  - 3.4.1 the accuracy and reliability with which the position of the helicopter can be determined;
  - 3.4.2 the inaccuracies in the indications of the altimeters used;
  - 3.4.3 the characteristics of the terrain (e.g. sudden changes in the elevation);
  - 3.4.4 the probability of encountering unfavourable meteorological conditions (e.g. severe turbulence and descending air currents);

- 3.4.5 possible inaccuracies in aeronautical charts; and
- 3.4.6 airspace restrictions.
- 3.5 **Heliports in congested areas.** Only Performance Class 1/Group A helicopters shall be permitted to operate from elevated heliports in congested areas.
- 3.6 **Elevated heliports or helidecks restriction.** Performance Class 3/Group B helicopters shall not be permitted to operate from elevated heliports or helidecks.
- 3.7 **Obstacle Data.** Obstacle data shall be provided for to enable operator to develop procedures for safe execution of the take-off/climb and approach/landing phases of a flight.

## 4. PERFORMANCES

### 4.1 General

- 4.1.1 **Significant factors.** To determine the performance of the helicopter, account is taken of at least the following factors:
  - (a) mass of the helicopter;
  - (b) elevation or pressure-altitude and temperature;
  - (c) wind. For take-off and landing, accountability for wind shall be no more than 50 per cent of any reported steady head wind component of 5 knots or more. Where take-off and landing with a tail wind component is permitted in the flight manual, not less than 150 per cent of any reported tail wind component shall be allowed. Where precise wind measuring equipment enables accurate measurement of wind velocity over the point of take-off and landing, these values may be varied; and
  - (d) operating techniques.
- 4.1.2 For performance Class 2 or 3 helicopters in any flight phase where a power-unit failure may cause the helicopter to force land:
  - (a) a minimum visibility must be defined by the operator, taking into account the characteristics of the helicopter, but never less than 1000m for performance Class 2 helicopters and 1 500 m for performance Class 3 helicopters;
  - (b) the operator is obliged to verify that the surface below the intended flight path permits the pilot to execute a safe forced landing; in addition, in case of a flight over water, the operator must also verify that the helicopter has been certificated for ditching.
- 4.1.3 In addition, performance Class 3 operations are not to be performed:
  - (c) out of the sight of the surface; or
  - (d) at night; or
  - (e) when the cloud ceiling is less than 180 m (600 ft).

### 4.2 Operating area considerations

- 4.2.1 **Touchdown and lift-off area.** On surface level heliports, the length or width of the

undercarriage, whichever is the greater, does not exceed 2/3 the diameter of the circle contained in the touchdown and liftoff area. On elevated heliports and on helidecks, it is presumed that the FATO and the touchdown and lift-off area will be coincidental.

4.2.2 **FATO.** The over-all length or width of the helicopter, whichever is the greater, does not exceed 2/3 the smallest dimension of the FATO except in case of a water heliport. In this case, it does not exceed 1/2 the width of the FATO. If the FATO includes water surface, the helicopter is to be specifically approved in its flight manual for routine water operations including rejected take-off onto water surfaces. For performance Class 1 helicopters, the dimensions of the FATO are not less than those which are indicated in the flight manual of the helicopter.

4.2.3 **Helicopter clearway.** The over-all length or width of the helicopter, whichever is greater, does not exceed 2/3 the width of the helicopter clearway in case of a land heliport or half the width of the helicopter clearway in case of a water heliport.

### 4.3 Limitations resulting from performance

#### 4.3.1 Performance Class 1 Helicopters

##### (a) Take-off

(1) No helicopter is taken off at a mass that exceeds the maximum take-off mass specified in the flight manual for the altitude of the heliport and for the ambient temperature existing at the time of the take-off.

(2) Take-off from a surface-level heliport (**Figure A-1**). The take-off mass is such that:

(a) the rejected take-off distance required does not exceed the rejected take-off distance available;

(b) the take-off distance required does not exceed the take-off distance available; or

As an alternative (**Figure A-2**), the take-off distance required may be disregarded provided that the helicopter with the critical power-unit failure at the TDP can, when continuing the take-off, clear all obstacles between the end of the take-off distance available and the point at which it becomes established in a climb at VTOSS by a vertical margin of 10.7 m (35 ft) or more. An obstacle is considered to be in the path of the helicopter if its distance from the nearest point on the surface below the intended line of flight does not exceed 30 m or 1.5 times the maximum dimension of the helicopter, whichever is greater.

(3) Take-off from an elevated heliport or helideck (**Figure A-3**). The take-off mass is such that:

(a) it is possible to reject the take-off and land on the FATO in case of the critical power-unit failure occurring before the TDP;

(b) it is possible to continue the flight if the critical power-unit failure occurs at or after the TDP. In this case, the flight path of the helicopter may descend below the height of the FATO in order to achieve VTOSS if the following conditions are satisfied:

- (1) A clearance margin is established in relation to the elevated heliport or helideck itself and to all obstacles located on the elevated heliport or helideck. 4.5 m (15 ft) has been found appropriate to a wide range of helicopters.
- (2) The vertical clearance above all obstacles not located on the elevated heliport or helideck is at least equal to 10.7m (35 ft). An obstacle is considered if its distance from the flight path does not exceed 30 m or 1.5 times the maximum dimension of the helicopter, whichever is greater.

(b) **Initial climb**

- (1) The take-off mass is such that the climb path provides a vertical clearance of not less than 10.7 m (35 ft) for VFR operations and 10.7 m (35 ft) + 0.01 DR for IFR operations above all obstacles located in the climb path, the critical power-unit failure occurring at the TDP.

- (2) An obstacle is considered if its lateral distance from the nearest point on the surface below the intended flight path does not exceed 30 m or 1.5 times the over-all length of the helicopter, whichever is greater, plus:

0.10 DR for VFR day operations

0.15 DR for VFR night operations

0.30 DR for IFR operations without electronic guidance

0.15 DR for IFR operations with electronic guidance

0.10 DR for IFR operations with ILS or MLS guidance except obstacles may be disregarded if they are situated beyond:

- (a) 7 rotor radius(R) for day operations if it is assured that navigational accuracy can be achieved by reference to suitable visual cues during the climb;
- (b) 10 R for night operations if it is assured that navigational accuracy can be achieved by reference to suitable visual cues during the climb;
- (c) 300 m if navigational accuracy can be achieved by navigation aids; and
- (d) 900 m in the other cases.

- (3) Where a change of direction of more than 15° is made, obstacle clearance requirements are to be increased by 5 m (15 ft) from the point at which the turn is initiated. This turn is not to be initiated before reaching a height of 30 m (100 ft) above the take-off surface.

- (c) **En route.** The take-off mass is such that it is possible, in case of the critical power-unit failure occurring at any point of the flight path, to continue the flight to an appropriate landing site and achieve the minimum flight altitudes for the route to be flown.

(d) **Approach, landing and balked landing (Figures A-7 and A-8).**

- (1) The estimated landing mass at the destination or alternate is such that:
  - (a) it does not exceed the maximum landing mass specified in the flight manual, taking into account the parameters specified in 4.1.1.

- (b) the landing distance required does not exceed the landing distance available;
  - (c) in case of the critical power-unit failure occurring at any point after the LDP, it is possible to land and stop within the FATO; and
  - (d) in case of the critical power-unit failure occurring at any point before the LDP, it is possible either to land and stop within the FATO, or to overshoot and clear all obstacles in the flight path by a vertical interval of 10.7 m (35 ft) for VFR plus an additional margin of 0.01 DR for IFR.
- (2) An obstacle is considered if its lateral distance from the nearest point on the surface below the intended line of flight does not exceed 30 m or 1.5 times the over-all length of the helicopter, whichever is greater, plus:
- 0.10 DR for VFR day operations
  - 0.15 DR for VFR night operations
  - 0.30 DR for IFR operations without electronic guidance
  - 0.15 DR for IFR operations with electronic guidance
  - 0.10 DR for IFR operations with ILS or MLS guidance except obstacles may be disregarded if they are situated beyond:
- (e) 7 R for day operations if it is assured that navigational accuracy can be achieved by reference to suitable visual cues during the climb;
  - (f) 10 R for night operations if it is assured that navigational accuracy can be achieved by reference to suitable visual cues during the climb;
  - (g) 300 m if navigational accuracy can be achieved by navigation aids; and
  - (h) 900 m in the other cases.
- (3) In case of a landing on an elevated heliport or helideck, the flight path may descend below the height of the landing surface in order to achieve VTOSS if the following conditions are satisfied:
- (a) A clearance margin is established in relation to the elevated heliport or helideck itself and to all obstacles located on the elevated heliport or helideck. 4.5 m (15 ft) has been found appropriate to a wide range of helicopters.
  - (b) The vertical clearance above all obstacles not located on the elevated heliport or helideck is at least equal to that specified in 4.3.1, d, i.

#### **4.3.2 Performance Class 2 Helicopters**

##### **(a) Take-off (Figures A-4 and A-5).**

- (1) The mass of the helicopter at take-off does not exceed the maximum take-off mass specified in the flight manual taking into account the parameters specified in 4.1.1.
- (2) The take-off mass is such that a safe forced landing can be achieved in the event of a power-unit failure prior to reaching the defined point after take-off.

(3) In case of a take-off from an elevated heliport or helideck and a failure of the critical power-unit occurring before  $V_y$  is obtained, the flight path may descend to achieve  $V_y$  if the following conditions are satisfied:

(a) A clearance margin is established in relation to the elevated heliport or helideck itself and to all obstacles located on the elevated heliport or helideck. 4.5 m (15 ft) has been found appropriate to a wide range of helicopters.

(b) The vertical clearance above all obstacles not located on the elevated heliport or helideck is at least equal to 10.7 m (35 ft). An obstacle is considered if its distance from the flight path does not exceed 30 m or 1.5 times the over-all length of the helicopter whichever is greater.

(b) **Initial climb**

(1) The take-off mass is such that the climb path provides a vertical clearance of not less than 10.7 m (35 ft) for VFR operations and 10.7 m (35 ft) + 0.01 DR for IFR operations above all obstacles located in the climb path, the critical power-unit failure occurring at the defined point after take-off.

(2) An obstacle is considered if its lateral distance from the nearest point on the surface below the intended flight path does not exceed 30 m or 1.5 times the over-all length of the helicopter, whichever is greater, plus:

0.10 DR for VFR day operations

0.15 DR for VFR night operations

0.30 DR for IFR operations without electronic guidance

0.15 DR for IFR operations with electronic guidance

0.10 DR for IFR operations with ILS or MLS guidance except obstacles may be disregarded if they are situated beyond:

(a) 7 R for day operations if it is assured that navigational accuracy can be achieved by reference to suitable visual cues during the climb;

(b) 10 R for night operations if it is assured that navigational accuracy can be achieved by reference to suitable visual cues during the climb;

(c) 300 m if navigational accuracy can be achieved by navigation aids; and

(d) 900 m in the other cases.

(c) **En route.** The take-off mass is such that it is possible, in case of the critical power-unit failure occurring at any point of the flight path, to continue the flight to an appropriate landing site and achieve the minimum flight altitudes for the route to be flown.

(d) **Approach, landing and balked landing (Figures A-9 and A-10)**

(1) The estimated landing mass at the destination or alternate is such that:

(a) it does not exceed the maximum landing mass specified in the flight manual, taking into account the parameters specified in 4.1.1;



- (b) a safe forced landing can be achieved in the event of an engine failure after reaching the defined point before landing;
  - (c) it is possible to perform a balked landing, all engines operating, at any point of the flight path and clear all obstacles in the flight path by a vertical clearance of not less than:
    - 10.7 m (35 ft) for VFR operations; and
    - 10.7 m (35 ft) + 0.01 DR for IFR operations; and
  - d) it is possible, in case of the critical power-unit failure occurring before the defined point before landing, either to land and stop within the FATO, or to overshoot and clear all obstacles in the flight path by a vertical interval of 10.7 m (35 ft).
- (2) An obstacle is considered if its lateral distance from the nearest point on the surface below the intended line of flight does not exceed 30 m or 1.5 times the over-all length of the helicopter, whichever is greater, plus:
- 0.10 DR for VFR day operations
  - 0.15 DR for VFR night operations
  - 0.30 DR for IFR operations without electronic guidance
  - 0.15 DR for IFR operations with electronic guidance
  - 0.10 DR for IFR operations with ILS or MLS guidance except obstacles may be disregarded if they are situated beyond:
- (e) 7 R for day operations if it is assured that navigational accuracy can be achieved by reference to suitable visual cues during the climb;
  - (f) 10 R for night operations if it is assured that navigational accuracy can be achieved by reference to suitable visual cues during the climb;
  - (g) 300 m if navigational accuracy can be achieved by navigation aids; and
  - (h) 900 m in the other cases.
- (3) In case of a landing on an elevated heliport or helideck, the flight path may descend below the height of the FATO in order to achieve  $V_y$  if the following conditions are satisfied:
- (a) A clearance margin is established in relation to the elevated heliport or helideck itself and to all obstacles located on the elevated heliport or helideck. 4.5 m (15 ft) has been found appropriate to a wide range of helicopters;
  - (b) The vertical clearance above all obstacles not located on the elevated heliport or helideck is at least equal to that specified in 4.3.3, d, (1).

### 4.3.3 Performance Class 3 Helicopters

#### (a) Take-off (Figure A-6)

- (1) The mass of the helicopter at take-off does not exceed the maximum

take-off mass specified in the flight manual taking into account the parameters specified in 4.1.1.

- (2) The take-off mass is such that a safe forced landing can be achieved in the event of an engine failure.

(b) **Initial climb**

- (1) The take-off mass is such that the climb path provides a vertical clearance of not less than 10.7 m (35 ft) above all obstacles located along the climb path, all engines operating.

- (2) An obstacle is considered if its lateral distance from the nearest point on the surface below the intended flight path does not exceed 30 m or 1.5 times the over-all length of the helicopter, whichever is greater, plus 0.10 DR, except obstacles may be disregarded if they are situated beyond 7 R.

- (c) **En route.** The take-off mass is such that it is possible to achieve the minimum flight altitudes for the route to be flown, all engines operating.

(d) **Approach, landing and balked landing (Figure A-11)**

- (1) The estimated landing mass at the destination or alternate is such that:
  - a) it does not exceed the maximum landing mass specified in the flight manual, taking into account the parameters specified in 4.1.1;
  - b) a safe forced landing can be achieved in the event of an engine failure;
  - c) it is possible to perform a balked landing, all engines operating, at any point of the flight path and clear all obstacles by a vertical interval of 10.7 m (35 ft).
- (2) An obstacle is considered if its lateral distance from the nearest point on the surface below the intended line of flight does not exceed 30 m or 1.5 times the over-all length of the helicopter, whichever is greater, plus 0.10 DR, except obstacles may be disregarded if they are situated beyond 7 R.

**DATO' IR KOK SOO CHON**  
**Director-General**  
**Department of Civil Aviation**  
**Malaysia**

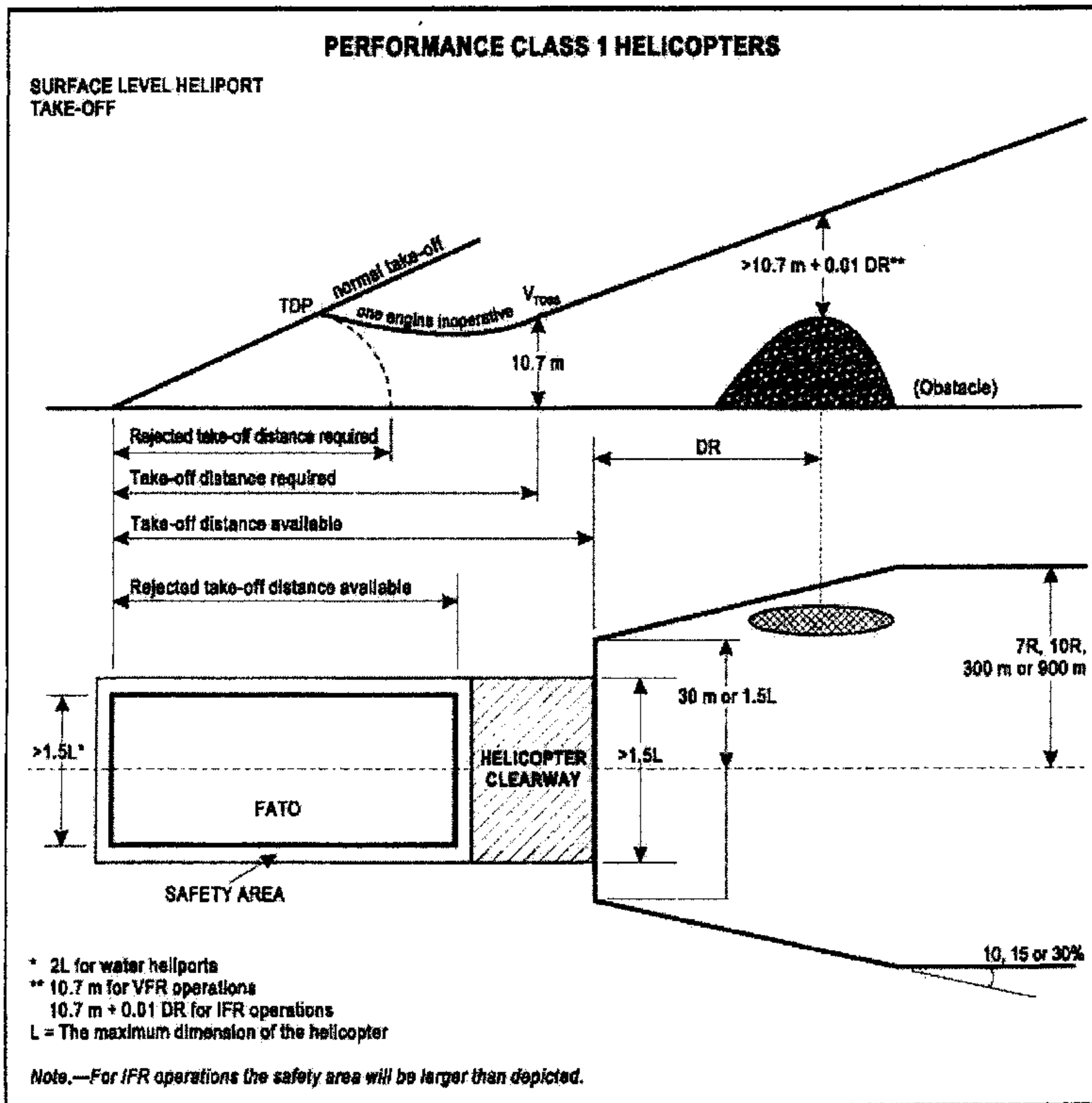

Figure A-1

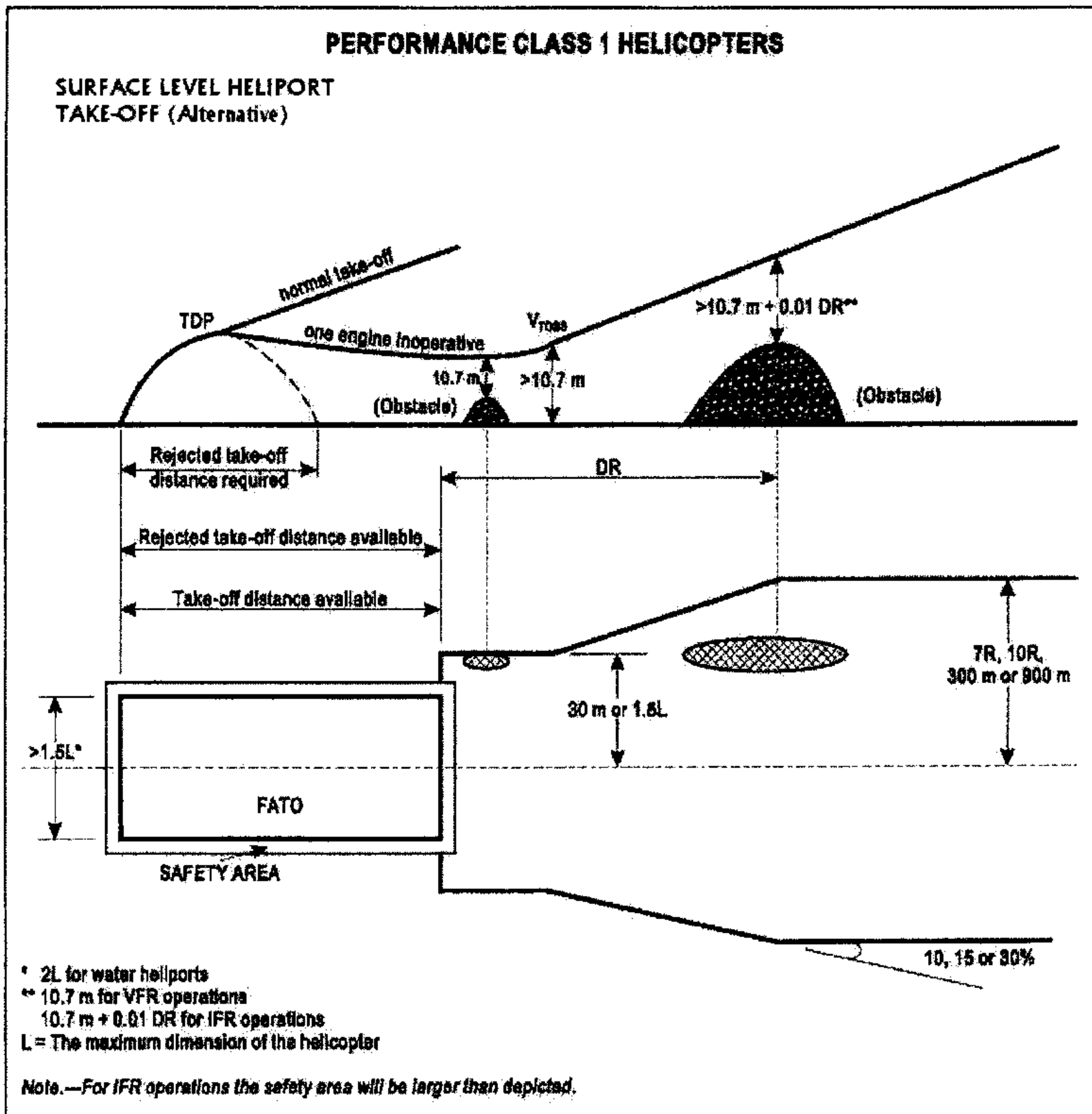

Figure A-2

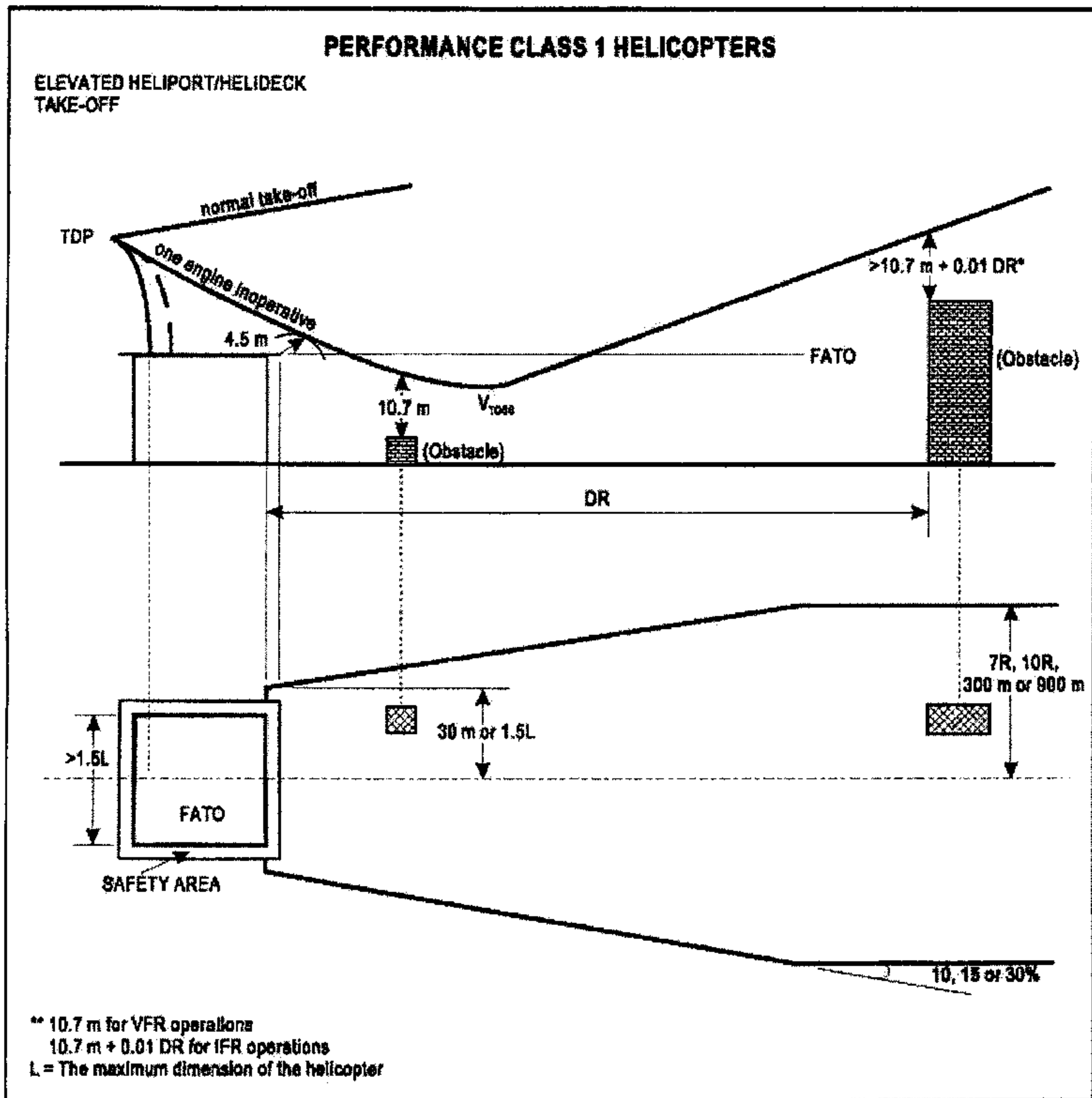

Figure A-3

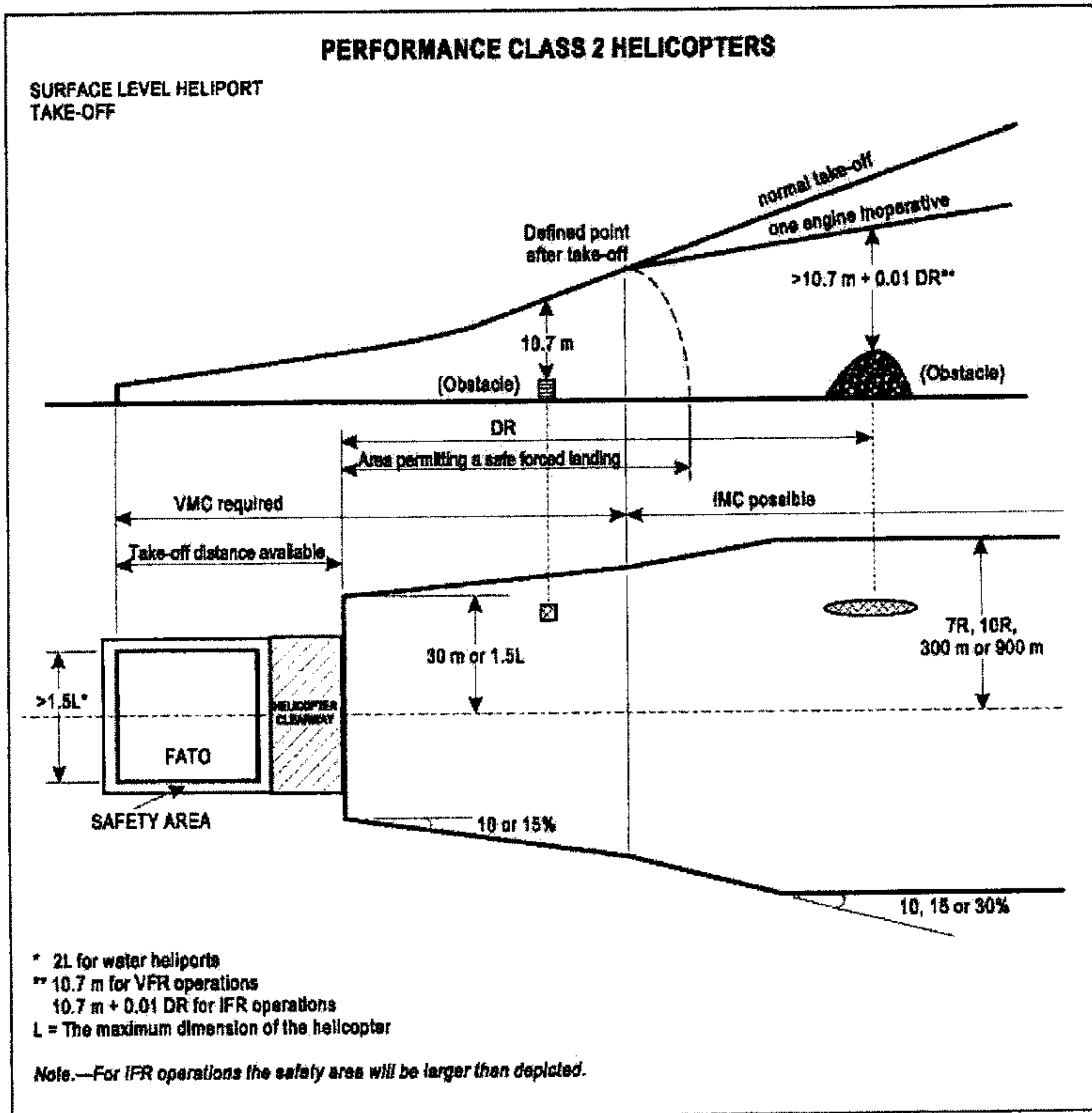

Figure A-4

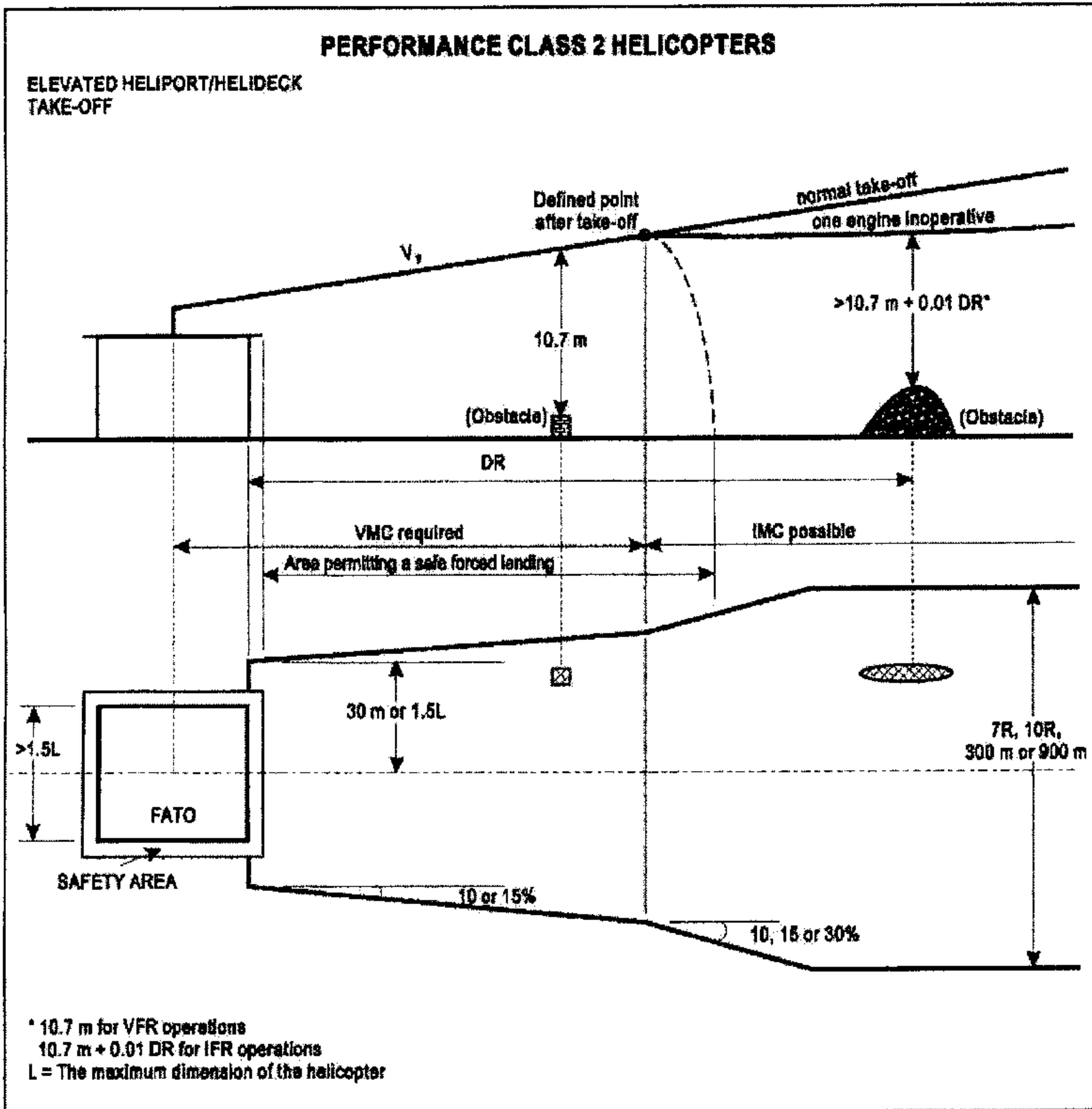

Figure A-5

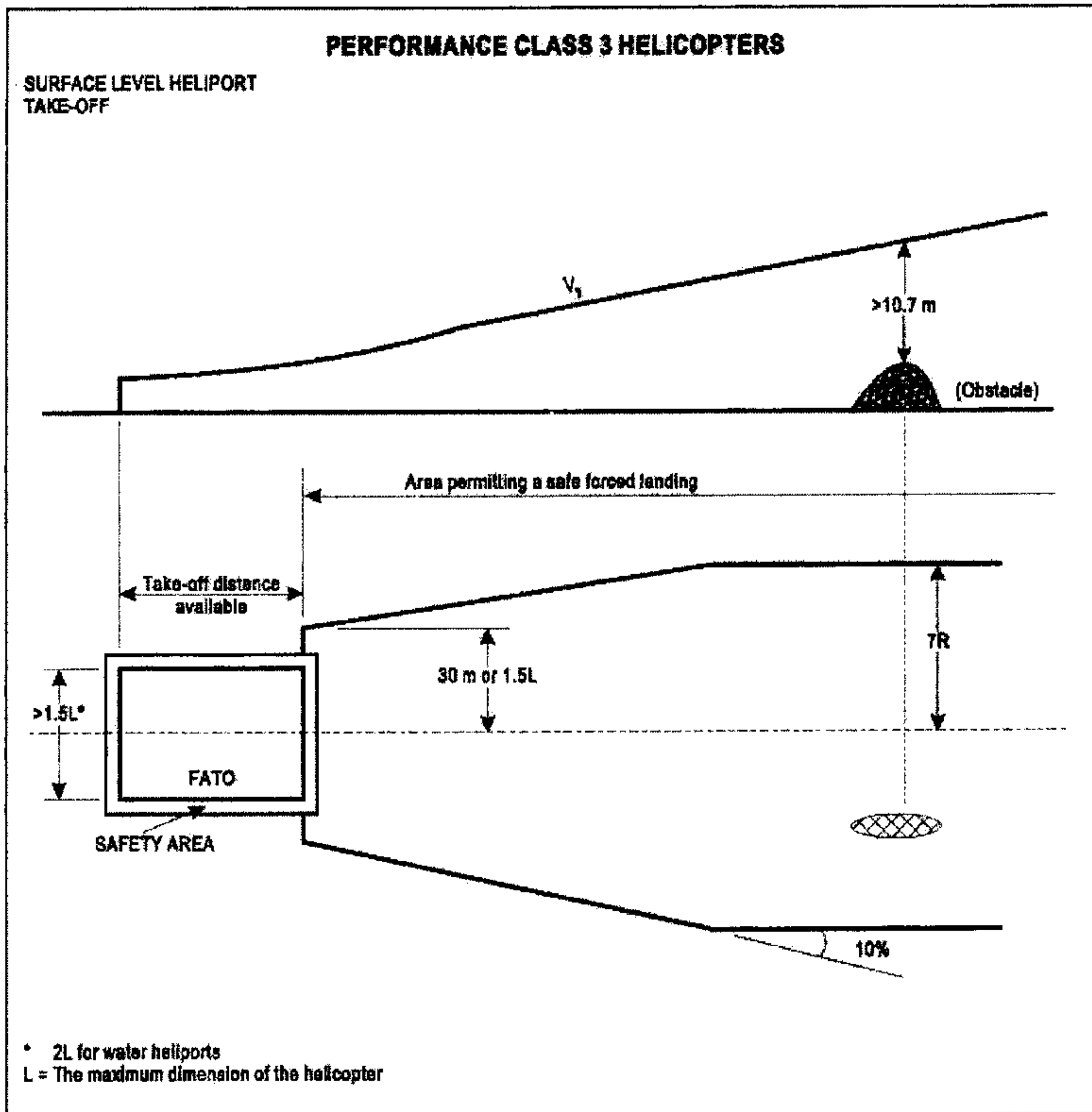

Figure A-6



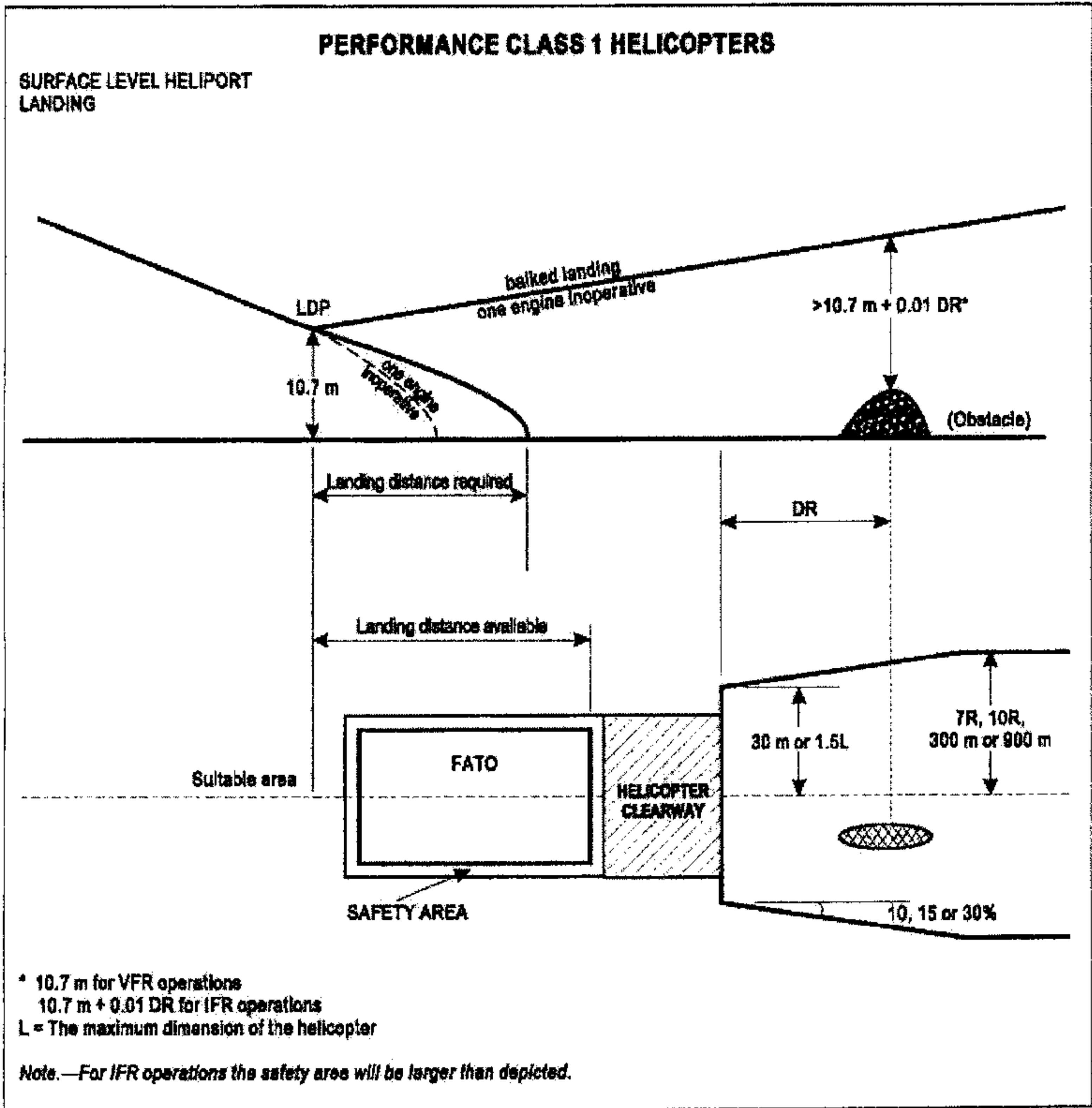

Figure A-7

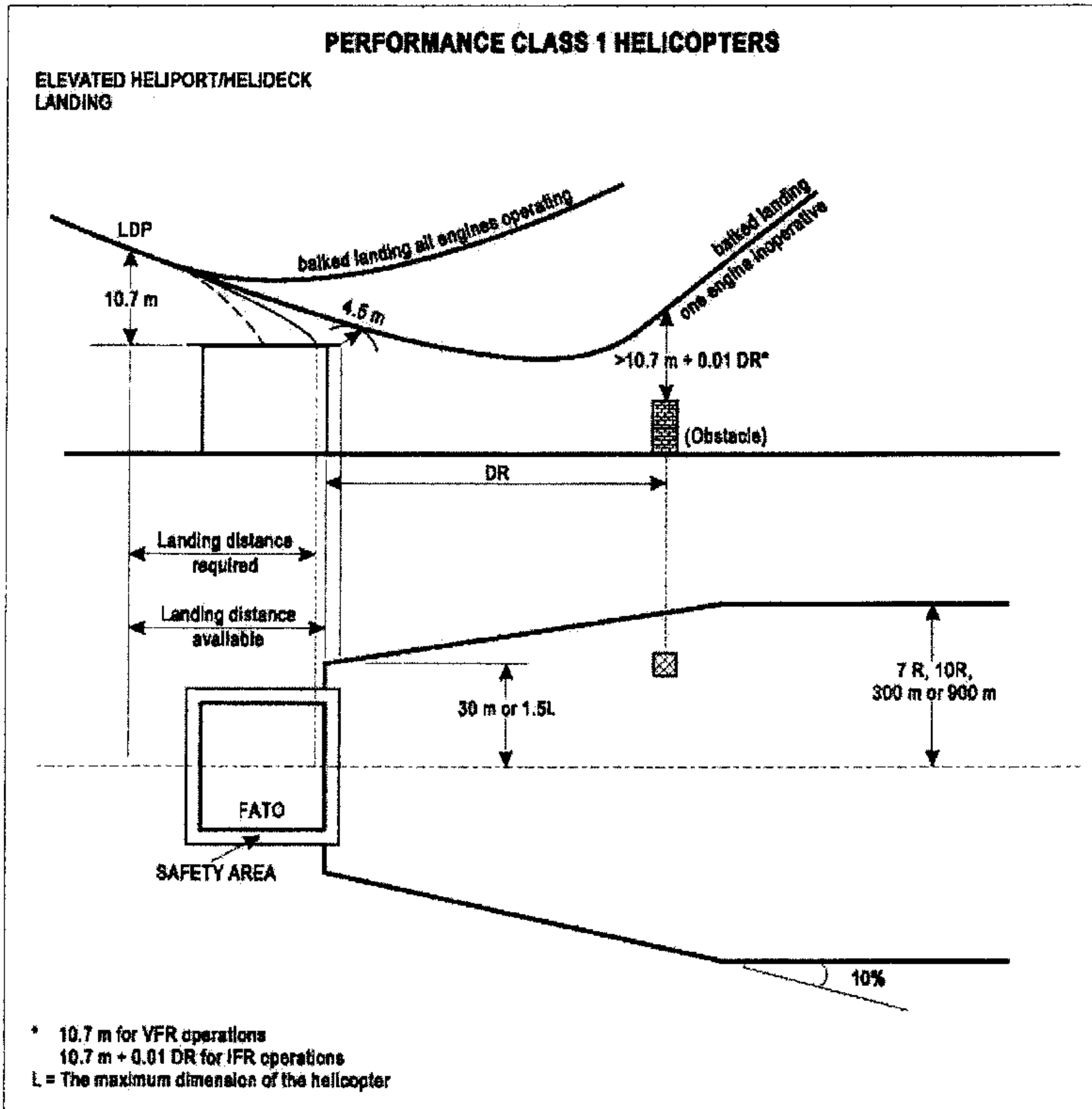

Figure A-8

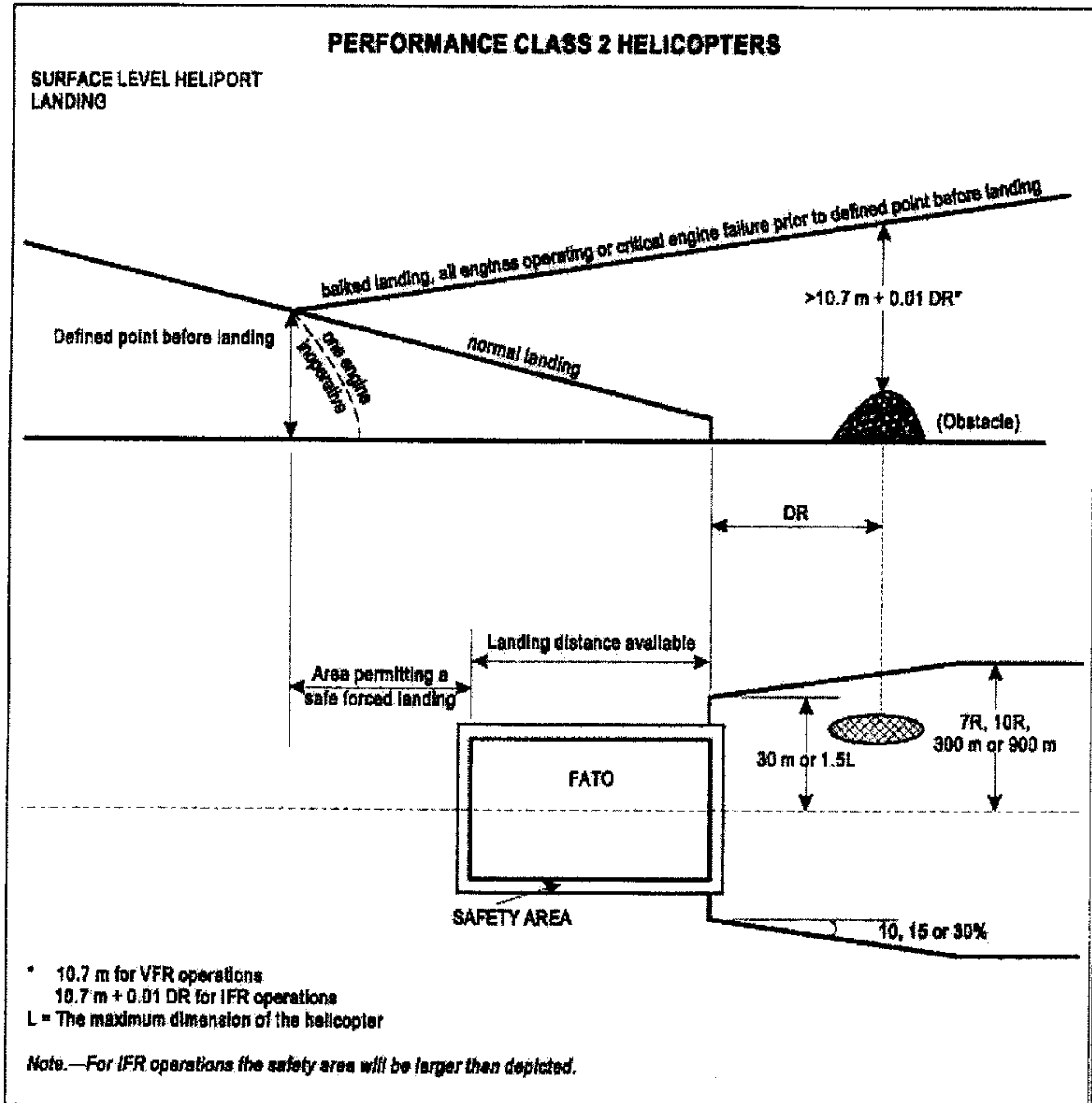

Figure A-9

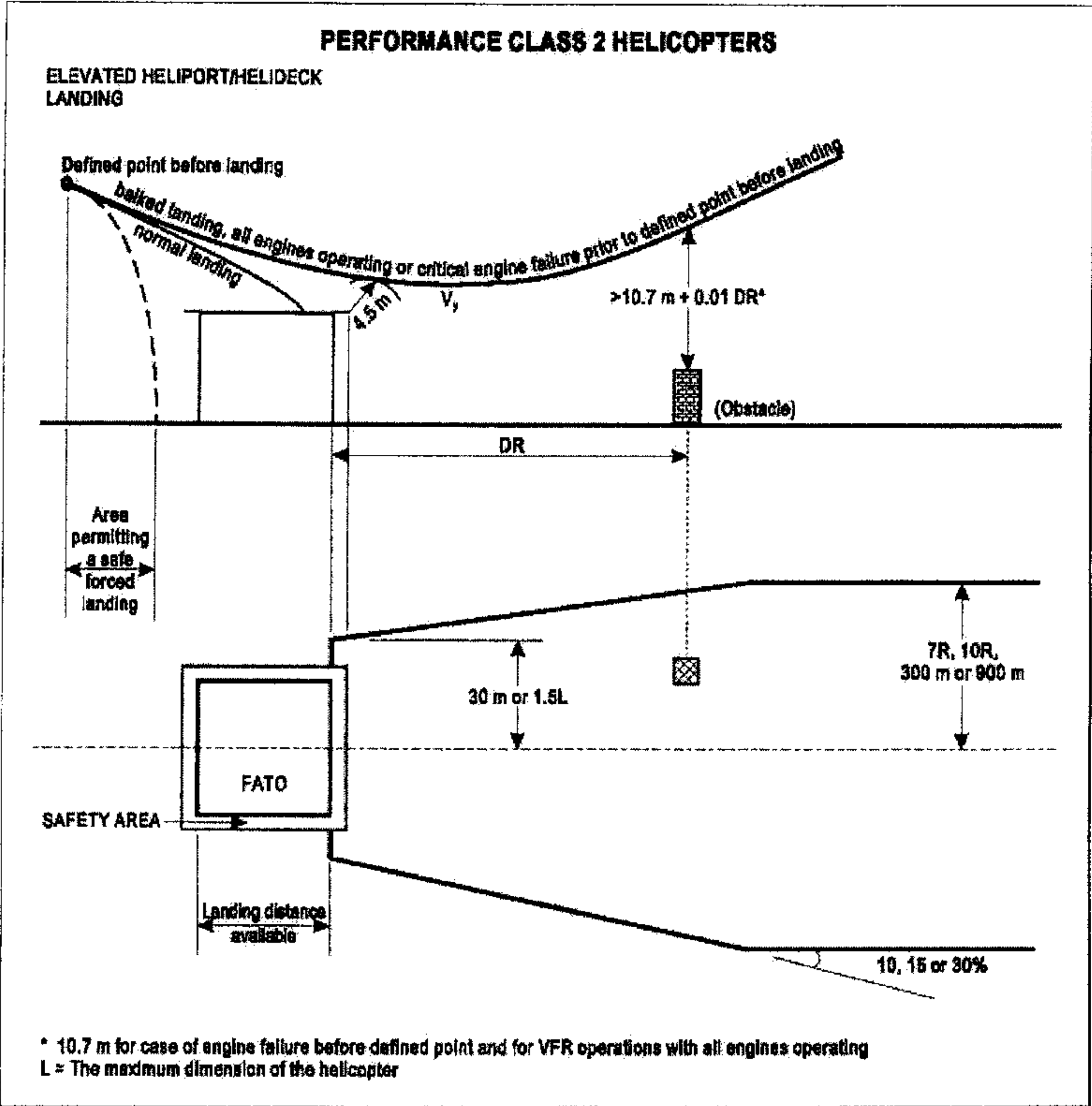

Figure A-10

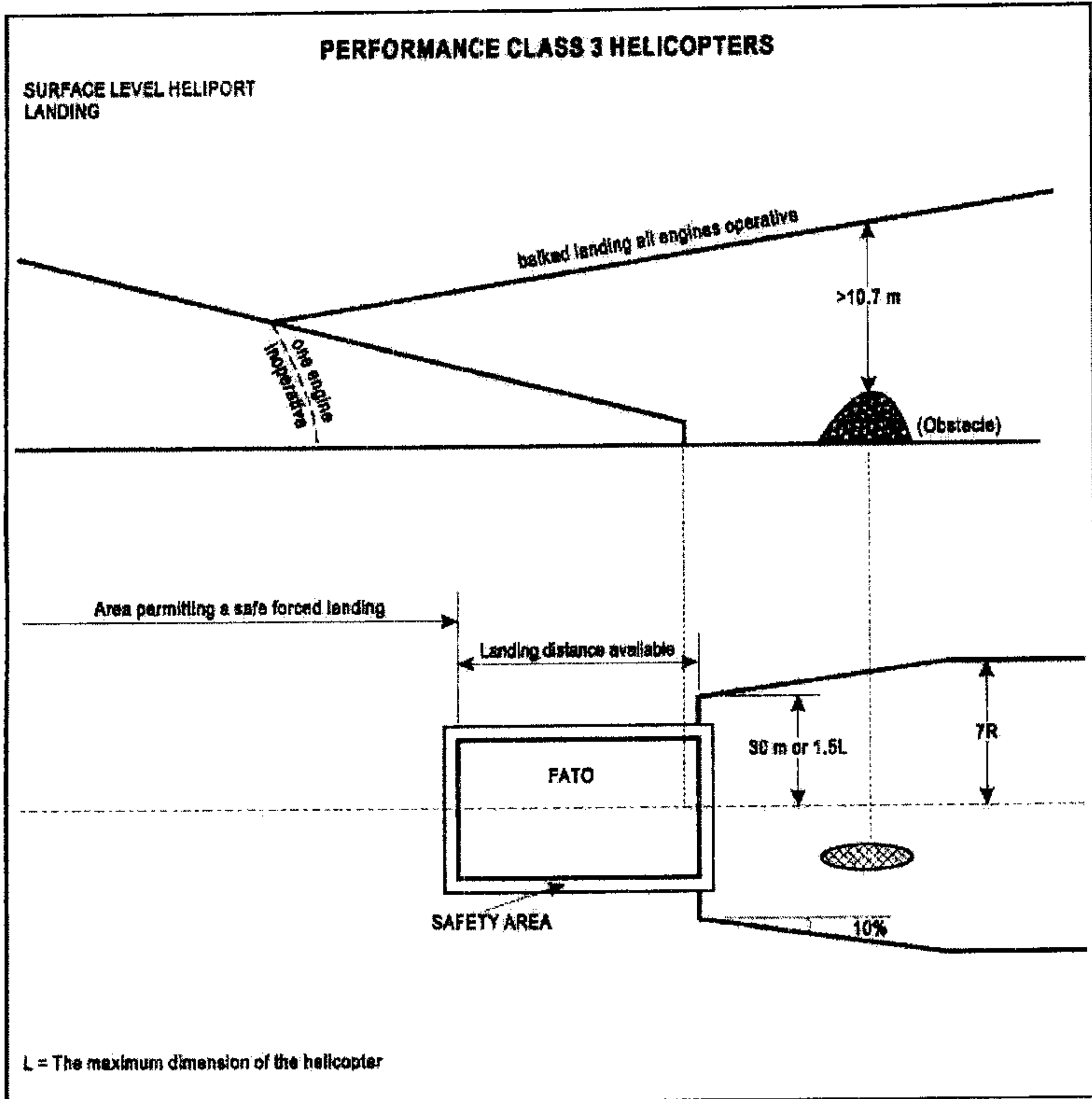

Figure A-11